

Mathematics Entrance Examination

17 May 2019

- 1. You have 1 hour and 10 minutes for the exam.**
- 2. Answer all questions.**
- 3. No calculators are allowed.**
- 4. Write your answers in the spaces below the questions. Answers with no evidence of calculations will not score any marks. Workings and answers written on any other page will not be marked.**

Please note additional requirements:

- a) You are not allowed to leave during the first 30 minutes or the last 15 minutes of the examination.
- b) If you are left handed or ambidextrous with left hand preference you should inform the invigilator before the start of the exam so that seating arrangements can fit your requirements.
- c) You are not allowed to talk, to whisper, to turn around or to look at another candidate's examination, all of which are offences and you will be penalized. If you commit this offence you will be given a single written warning; after which if you commit a further offence, you will be reported to an assessment board without a right of appeal or refund of the exam administration fee.
- d) No scrap paper may be used. All work must be written in the exam booklet.
- e) You can use non-erasable blue or black pen only. Any answers written in pencil may not be marked.
- f) You cannot use whiteout/correction fluid. If you use this material to correct any of your answers they may not be marked. If you make a mistake, you should simply draw a line through the mistake with pen and continue.
- g) You cannot borrow another student's stationery or materials.
- h) If your pen runs out of ink, you may request a replacement from the invigilator. No other stationery or materials may be provided for you by the invigilator.
- i) If you are found to have any unauthorized exam related materials during the examination this will constitute an offence and you will be disqualified from the exam without a right to claim the reimbursement of the exam administration fee.
- j) If you are caught cheating in the examination, you will be disqualified from the exam without a right to claim the reimbursement of the exam administration fee.
- k) Failure to show contents of your pockets or any other containers to the invigilators will be considered as an offence and you will be disqualified from the exam with no right of appeal or refund of the fee.
- l) All mobile phones and other electronic devices must be switched off and left at a place indicated by the invigilators. If you are found to have a mobile phone or other electronic device (switched on or off) on you during the exam, this will be considered as unauthorised examination materials and you will be disqualified from the exam without a right of appeal or refund of the fee.

Applicant ID:

All questions on this paper must be answered.

Write the answers in the space below each question.

Show **ALL** working for each question.

1. The table shows the results of a test for pulse rate (heartbeat) carried out on 274 children.

	Boys	Girls	Total
High Pulse	58	71	129
Low Pulse	83	62	145
Total	141	133	274

Round your answers to the nearest whole number

a) What percentage of the boys had a low pulse rate?

.....

(2 marks)

b) What percentage of the children with a high pulse rate were girls?

.....

(2 marks)

2. Oil has a density of 800 kg/m^3

Convert this density into g/cm^3

.....

(2 marks)

Total marks for page: 6 marks

3. If $a = 3.1$ and $b = 7.3$, correct to 1 decimal place, find the largest possible value of $a + b$

.....

(3 marks)

4. Simplify

a) $7w^{-2} \times 3w^{-1}$

.....

(2 marks)

b) $5y^3 \div 2y^{-2}$

.....

(2 marks)

Total marks for page : 7 marks

5.

a) On the grid below, plot the line $y = 2x + 2$ (1 mark)

b) Plot the curve $y = x^2 - 1$ (2 marks)

c) **Using the graph**, find the co-ordinates of the two points of intersection.

(Marks will be deducted if the graph is not used.)

i) (.....,.....) (2 marks)

ii) (.....,.....) (2 marks)

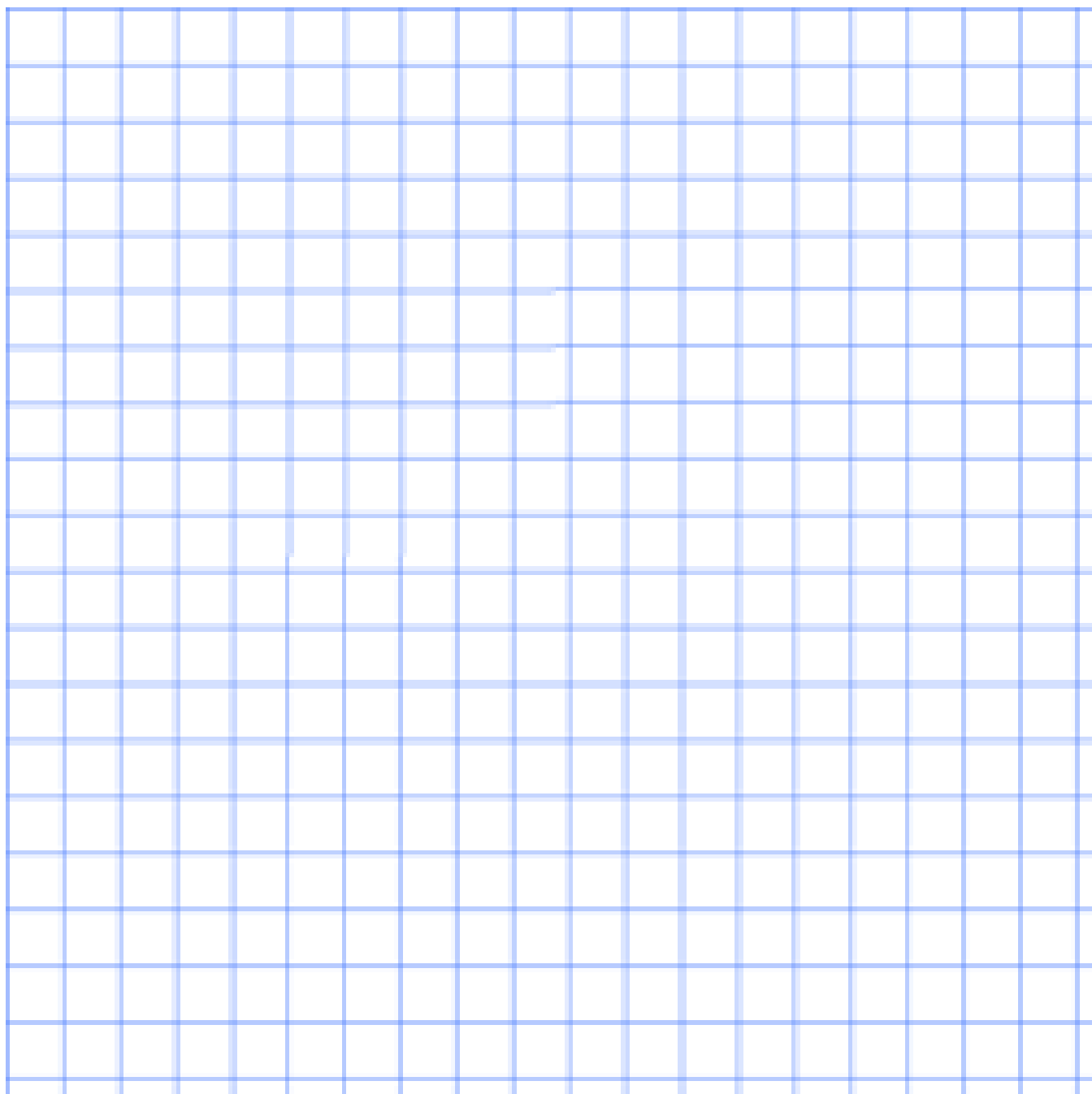

Total marks for page: 7 marks

6a).Solve the following simultaneous equation

$$3x - y = 17$$

$$\frac{x}{5} + \frac{y}{2} = 0$$

$$x = \dots\dots\dots$$

$$y = \dots\dots\dots$$

(4 marks)

b)Make x the subject of the formula

$$\sqrt{(ax + b)} = c$$

$$\dots\dots\dots$$

(2 marks)

c) Solve the inequality

$$10 \leq 2x \leq x + 9$$

$$\dots\dots\dots$$

(2 marks)

Total marks for page: 8 marks

7.

80 machines can produce 4800 identical dolls in 5 hours.

At this rate

a) How many dolls can 1 machine produce in 1 hour?

.....

(3 marks)

b) How many dolls would 25 machines produce in 7 hours?



.....

(3 marks)

c) y is inversely proportional to x , and $y = 8$ when $x = 3$

What is the value of y when $x = 4$?

.....

(2 marks)

Total marks for page: 8 marks

8. A rectangular matchbox measures 12 cm by 5 cm by 3 cm. Each match is a cuboid, 5 cm by 2 mm by 2 mm.

What is the greatest number of matches which can fit into a box?



.....
(4 marks)

9. The n th term of the sequence 6, 14, 24, 36.... is $n^2 + kn$
Find k

.....
(2 marks)

Total marks for page: 6 marks

10.



'Lavender fire' paint is made by mixing red and blue paint in the ratio 3 : 1

'Lavender sea' paint is made by mixing red and blue paint in the ratio 1 : 3

1 litre of Lavender fire paint is mixed with 500 millilitres of Lavender sea by mistake.

How much red paint needs to be added to the mixture to make it Lavender fire again?

.....
(5 marks)

Total marks for page: 5 marks

11. Find the missing numbers

a) $0.2 \times \square = -200$

(2 marks)

b) $\square - (-8) = 0$

(2 marks)

12. a) Simplify

$$\frac{5ab}{15a + 10a^2}$$

.....

(2 marks)

b) Write as a single fraction

$$\frac{2}{x+3} - \frac{3}{x-4}$$

.....

(2 marks)

Total marks for page : 8 marks)

c)Cancel

$$\frac{x^2 + 2x}{x^2 + 5x + 6}$$

.....
(2 marks)

d)Solve

$$\frac{5(2x+3)}{2x}=4$$

.....
(2 marks)

13.

Work out the following and give your answer in standard form

$$(6 \times 10^5) \div (5 \times 10^{-3})$$

.....
(2 marks)

Total marks for page: 6 marks

14.

A 20° sector is cut from a round cheese.

The radius of the slice is 6 cm.

The height of the slice is 3 cm.

Find the volume of the slice of cheese,

Use 3.14 as the value of π . Round your answer to the nearest whole number

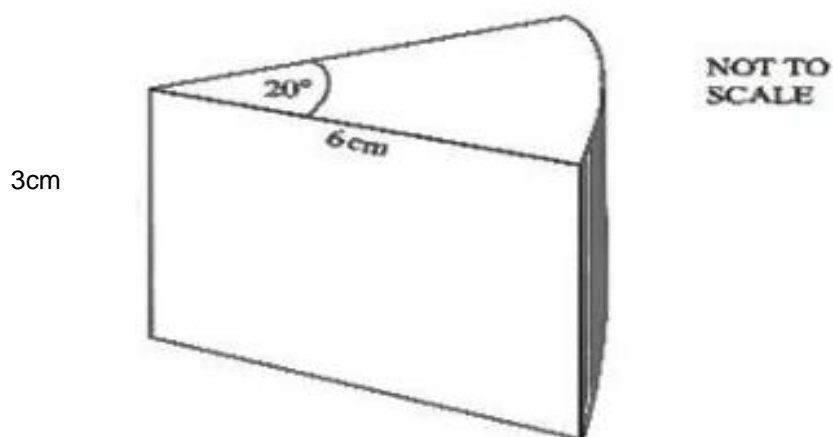

.....

(6 marks)

Total marks for page: 6 marks

15. Here are three lamps.

lamp A



lamp B



lamp C



Lamp A flashes every 20 seconds.

Lamp B flashes every 45 seconds.

Lamp C flashes every 120 seconds.

The three lamps start flashing at the same time.

How many times in one hour will the three lamps flash at the same time?

Total marks for page: 3 marks

END OF TEST.
DO NOT WRITE ON THIS PAGE.